

USE AND MAINTENANCE MANUAL

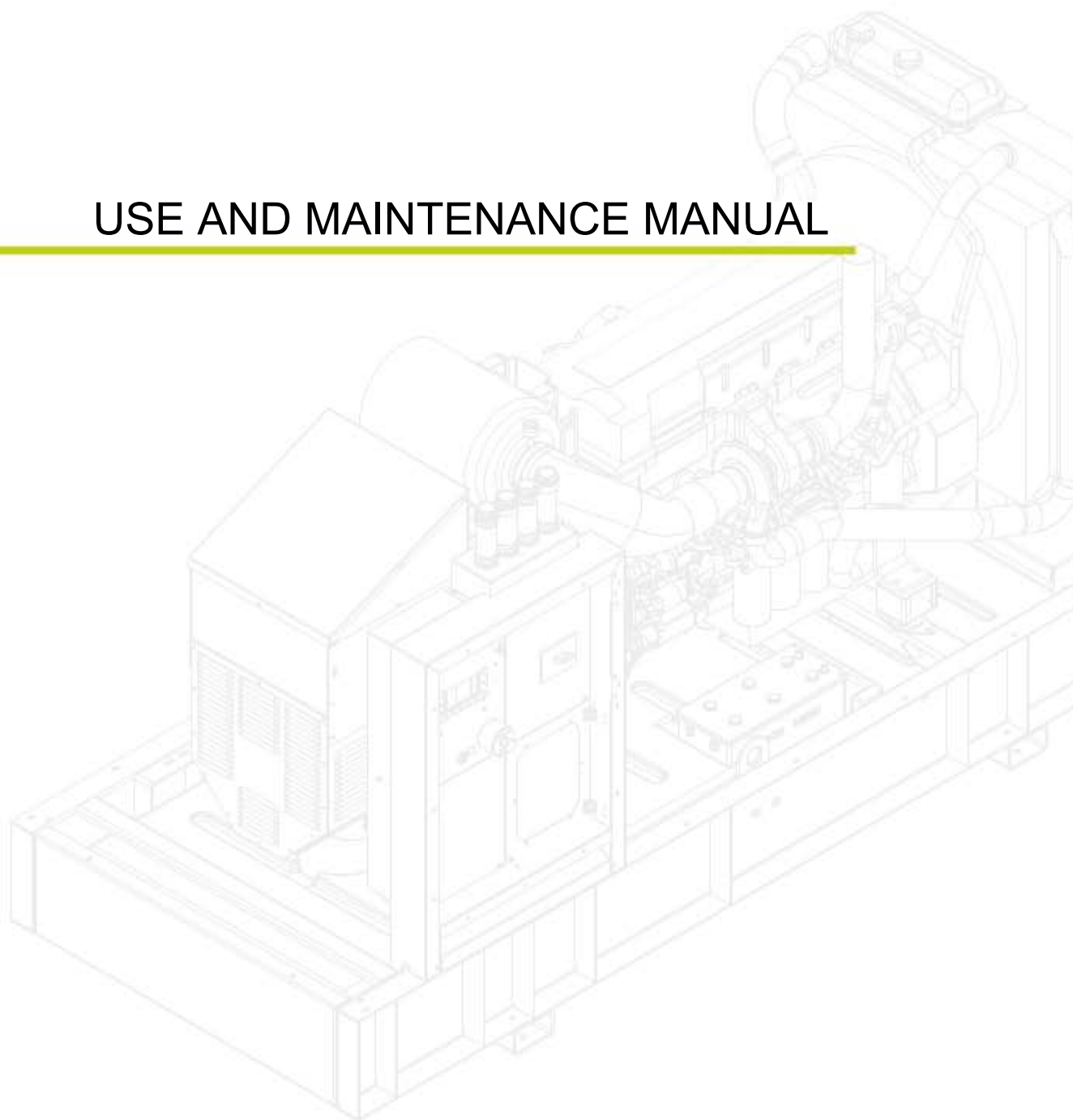

ENERGY GENERATION

PRAMAC
www.pramac.com

CE

**TRANSLATION OF THE
ORIGINAL INSTRUCTIONS
(ORIGINAL INSTRUCTIONS
IN ITALIAN)**

GENERAL INDEX

1 FOREWORD	3		
1.1 Preamble	4		
1.2 Symbols	4		
1.3 Purpose of the manual and its preservation	4		
1.4 Whom this manual is intended for and personnel qualification	4		
1.5 Technical assistance and spare parts service	5		
2 DESCRIPTION AND TECHNICAL DATA	6		
2.1 Identification of the generator	7		
2.2 Certification of the generator	7		
2.3 CE Declaration of Conformity	8		
2.4 Description of the generator	8		
2.5 Technical data	9		
2.5.1 Overall dimensions	9		
3 SAFETY	10		
3.1 Intended use	11		
3.2 Reasonably foreseeable misuse	11		
3.3 Use of personal protective equipment (PPE)	12		
3.4 Safety and warning signs	12		
3.5 Airborne noise emission	14		
4 INSTALLATION	15		
4.1 Transport and positioning	16		
4.1.1 Lifting the generator with adjustable chains	16		
4.1.2 Lifting the generator with a forklift	19		
4.1.3 Transport and storage	19		
4.1.4 Positioning	20		
4.2 Connecting the utilities	20		
4.2.1 Cable dimensions	20		
4.2.2 Cable arrangement	20		
4.2.3 Earthing the masses	21		
4.2.4 Implementing the electrical connections	21		
4.3 Connections for the automatic start up of the generator	24		
4.4 Commissioning operations	24		
4.4.1 Visual checks	24		
4.4.2 Checking the engine oil level	24		
4.4.3 First fuel fill-up	24		
4.4.4 Connecting the battery cables	24		
4.5 Start up operations after a long idle period	25		
5 USE	26		
5.1 Safety precautions for use	27		
5.2 Preliminary checks for use	27		
5.3 Generator control panel	28		
5.4 Electronic control board commands	30		
5.5 Starting up the generator	31		
5.6 Stopping the generator	32		
5.7 Emergency stop of the generator	33		
5.8 Manual refuelling	33		
5.9 Using the generator at high altitudes or high ambient temperatures	35		
6 MAINTENANCE	36		
6.1 Importance of maintenance	37		
6.2 Safety precautions for maintenance	38		
		6.3 Electrical maintenance interventions	38
		6.3.1 General checks on the electrical system	38
		6.3.2 Checking the battery	39
		6.4 Checking the alternator	39
		6.5 Mechanical maintenance interventions	40
		6.5.1 Checking and topping up the engine oil level	40
		6.5.2 Changing the engine oil and filter	40
		6.5.3 Verifying the coolant level and topping up	40
		6.5.4 Replacing the coolant filter	41
		6.5.5 Replacing the air filter	41
		6.5.6 Replacing the fuel pre-filter and filter	42
		6.5.7 Draining fuel from the tank	42
		6.6 Maintenance schedule	43
		6.6.1 Electrical system maintenance schedule	43
		6.6.2 Maintenance schedule of the mechanical parts	43
		7 TROUBLESHOOTING	44
		7.1 Problems, causes and solutions	45
		8 PLACING OUT OF SERVICE AND SCRAPPING	47
		8.1 Safety when placing out of service and scrapping	48
		8.2 Placing out of service for long periods	48
		8.3 Decommissioning and scrapping	49
		8.3.1 Special waste disposal requirements	49
		9 SPECIFICATIONS	50
		9.1 Information concerning lubricants, liquids and coolants	51
		9.2 Derating due to environmental conditions	53
		10 ROUTINE AND EXTRAORDINARY MAINTENANCE LOG	54

1 FOREWORD

1 FOREWORD	3
1.1 Preamble	4
1.2 Symbols	4
1.3 Purpose of the manual and its preservation	4
1.4 Whom this manual is intended for and personnel qualification	4
1.5 Technical assistance and spare parts service	5

1.1 Preamble

Thank you for having purchase this generator!

This manual is an integral part of the purchased generator and provides useful guidelines for it to work properly and for maintenance purposes. It is mandatory to refer to the instructions provided for your own safety and that of the persons involved and the manufacturer must always be contacted if any doubt should arise from the lack of or difficulty in understanding the instructions.

This manual does NOT replace the laws and local regulations in any way. Always comply with the law and local regulations in the place where the generator is used.

- This manual must always accompany the generator throughout the operating period.
- The “original instructions” are compiled in ITALIAN.
- Any other language is a “translation of the original instructions”, in compliance with that stipulated by the EU Directive 2006/42/EC.
- All rights for reproduction of this manual are reserved to the manufacturer.
- The descriptions and illustrations provided in this publication are not binding. The manufacturer reserves the right to make any change deemed necessary at any time and without prior notice.
- This manual cannot be reproduced or disclosed to third parties without written authorisation from the manufacturer.

1.2 Symbols

The following symbols and styles of the text listed below are used in the manual to communicate information regarding:



DANGER

Indicates a situation of imminent risk, which can cause serious or fatal injuries if not avoided.



WARNING

Indicates a situation of potential risk, which can cause serious or fatal injuries if not avoided.



ATTENTION

Indicates a situation of potential risk, which can cause slight to moderate injuries if not avoided.



NOTE

Indicates the obligation for certain behaviour or special activities for the machine to be handled safely.

1.3 Purpose of the manual and its preservation

In compliance with that stipulated in the Machinery Directive 2006/42/EC, this manual provides the information regarding safety and the lifetime phases of the generator (transport, installation, use, maintenance and disposal).

- Carefully read and understand this technical publication before operating on the generator and/or adjusting and/or servicing.
- If in doubt while consulting this manual, always contact the manufacturer before commencing any operation.
- Please contact the expert personnel of the manufacturer to resolve any problem that may arise during the operating lifetime of the generator as soon as possible, which has not been covered in this technical publication.
- The manufacturer declines any liability related to non-compliance of that stipulated in this manual.
- Keep this manual and all the attached publications in a safe place, which is accessible and known to all the users of the generator.

1.4 Whom this manual is intended for and personnel qualification

The generator has been designed to be used by duly qualified personnel and the content of this manual is intended for such personnel.

The personnel must receive adequate technical training and be familiar with commonly used tools: spanners, screwdrivers, etc.

The personnel must have read and understood this entire manual. The operator must be aware of the operating modes of the generator, be able to follow the user instructions provided in the manual and pay utmost attention when using the generator.

Besides hazards deriving from electricity, those related to explosive and flammable substances must be considered (fuel and lubricating oils) as well as those related to moving parts, combustion gases, hot parts and waste products one can come in contact with (e.g. spent lubricant, coolant, etc.).

1.5 Technical assistance and spare parts service

In order to guarantee after-sales service of the purchased generator to the users and a continuous update on the range of products and solutions, the manufacturer provides the following services on internet.

A) Technical assistance and spare parts service.

A technical area that allows you to contact qualified operators whom to refer to, to request assistance and spare parts.

<http://www.pramacparts.com>

B) A sales and products area.

The main area for products and solutions from where you can access the sales department and sales network.

<http://www.pramac.com>

2 DESCRIPTION AND TECHNICAL DATA

2 DESCRIPTION AND TECHNICAL DATA	6
2.1 Identification of the generator	7
2.2 Certification of the generator	7
2.3 CE Declaration of Conformity	8
2.4 Description of the generator	8
2.5 Technical data	9
2.5.1 Overall dimensions	9

2.1 Identification of the generator

The generator is identified by a special identification plate (1), which is compliant with the requirements of the Machinery Directive 2006/42/EC, affixed on the metal frame.



WARNING

It is strictly prohibited to remove the identification plate (1) from the generator or to alter or delete the data on the plate itself.



NOTE

The identification plate (1) is designed to last. However, it is recommended to take note of the data on the plate in order to have them stored. Contact the manufacturer if the plate must be replaced.

OPENSET

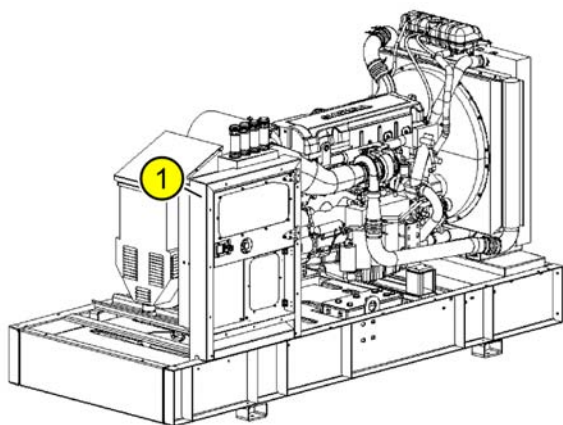

SOUNDPROOF

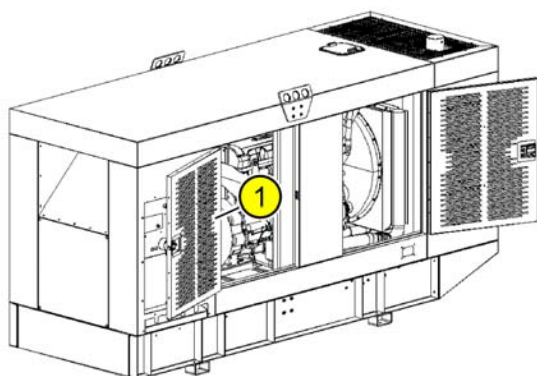

The “CE” symbol (2) may not be present on the plate. Refer to the following "Certification of the generator" paragraph for further details.

TECHNICAL SPECIFICATIONS		MADE IN	
TYPE	MODEL	<input type="text"/>	
S/N	YEAR	<input type="text"/>	<input type="text"/>
ENGINE	S/N	<input type="text"/>	<input type="text"/>
ALTERNATOR	S/N	<input type="text"/>	<input type="text"/>
SPEED	R.P.M	WEIGHT	<input type="text"/> KG
PRIME POWER	<input type="text"/> KVA	<input type="text"/> KW	
STANDBY POWER	<input type="text"/> KVA	<input type="text"/> KW	
FREQUENCY	<input type="text"/> Hz	COSPHI	<input type="text"/>
RATED VOLTAGE	<input type="text"/> V	MAX. CURRENT	<input type="text"/> A

The generator is uniquely identified according to the model (3), the machine code (4), the serial number (5) and the year of manufacture (6).



NOTE

The model data plate (3), machine code (4), serial number (5) and year of manufacture (6) may be asked for if technical assistance is requested. The plate also indicates the weight (7) of the generator including the circuit liquids (oil, coolant, etc.) excluding the fuel. Consult this information before proceeding with the lifting operations.

2.2 Certification of the generator

The generators marketed within the European Community are accompanied by the relative CE Declaration of Conformity, Annex IIA, of the EU Directive 2006/42/EC. In this case, the identification plate bears the “CE” symbol (see the “identification of the generator” paragraph).

The generators that do not belong to the category described previously are constructed in compliance

with the technical standards harmonised with the EU Directive 2006/42/EC, however, they are not accompanied by the CE Declaration of Conformity; in this case, the identification plate does not bear the "CE" symbol (see the "identification of the generator" paragraph).

2.3 CE Declaration of Conformity

The CE Declaration of Conformity is attached to this instruction manual

2.4 Description of the generator

The paragraph identifies the main components of the generator, which are normally supplied as standard. Additional components, called "extras" can be installed.

The generator is supplied with different diesel engines and rated power outputs based on the specific model.

Another difference is the possibility of choosing between the **OPEN SET** and the **SOUNDPROOF** model. The **OPEN SET** model is made up of a bearing base upon which the main components are mounted (engine, alternator, control panel, etc.).

The **SOUNDPROOF** generator, built with the same criteria as **OPEN SET**, is equipped with soundproof panels which completely enclose all the main components mounted on the base.

SOUNDPROOF

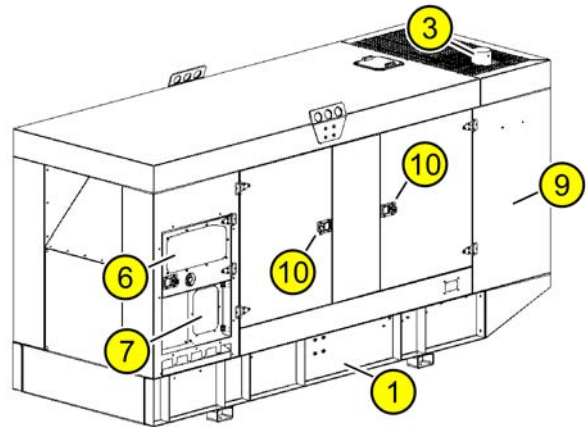

NOTE

Both models must be installed by trained and qualified personnel. In particular, OPEN SET models installed within the European Community must be positioned in a safe place, which is only accessible to trained and qualified personnel and sufficiently sheltered against the direct action of atmospheric agents.

OPEN SET

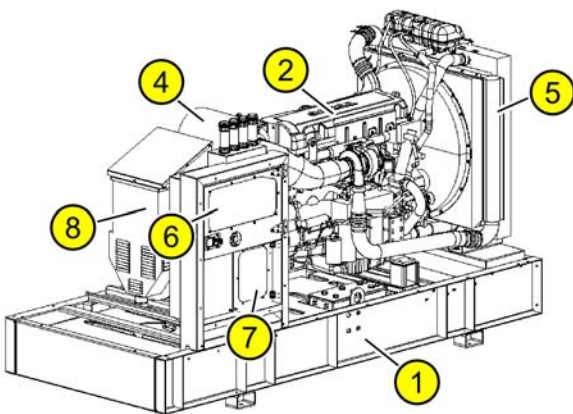

#	Component
1	Base
2	Engine
3	Silencer
4	Air filter
5	Radiator
6	Control panel
7	Utilities connection
8	Alternator
9	Soundproof panels
10	Doors

2.5 Technical data

2.5.1 Overall dimensions

The overall dimensions provided refer to the models listed in the table.

OPEN SET

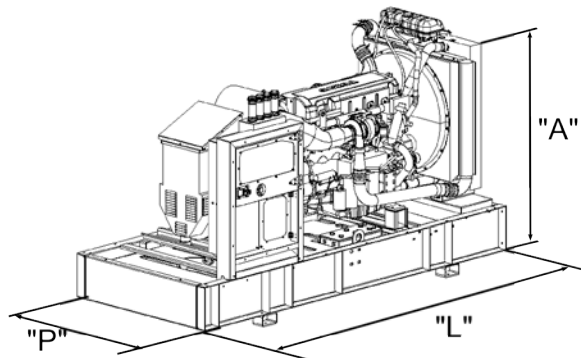

Refer to the data provided in the technical installation drawing supplied for the **overall dimensions**.

Refer to the plate applied to the machine for the **weight** and **sound emission level** (measured according to the reference standard **ISO8528-10**).

SOUNDPROOF HIGH CAPACITY TANK

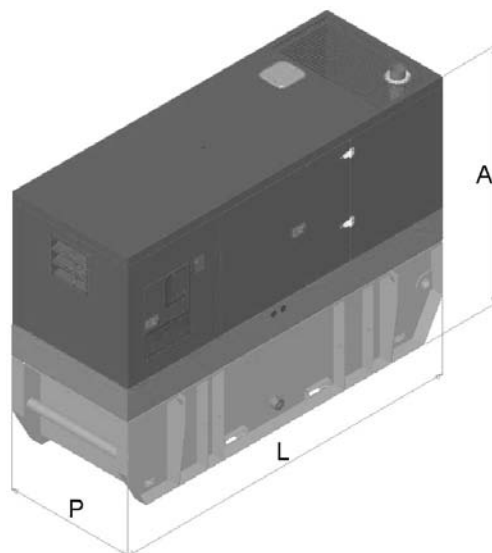

Refer to the data provided in the technical installation drawing supplied for the **overall dimensions**.

Refer to the plate applied to the machine for the **weight** and **sound emission level** (measured according to the reference standard **ISO8528-10**).

SOUNDPROOF

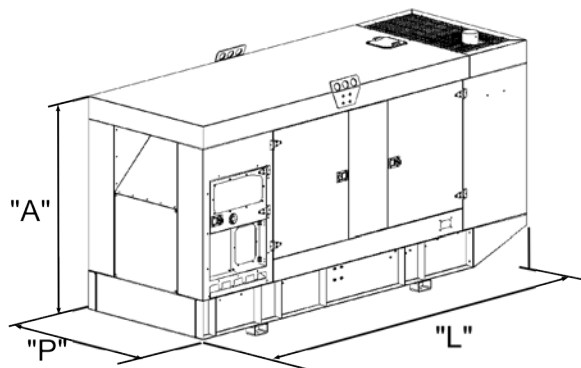

Refer to the data provided in the technical installation drawing supplied for the **overall dimensions**.

Refer to the plate applied to the machine for the **weight** and **sound emission level** (measured according to the reference standard **ISO8528-10**).

3 SAFETY

3 SAFETY	10
3.1 Intended use	11
3.2 Reasonably foreseeable misuse	11
3.3 Use of personal protective equipment (PPE)	12
3.4 Safety and warning signs	12
3.5 Airborne noise emission	14

3.1 Intended use

The generators described in this manual are designed and built for professional use to supply electricity by means of a combustion engine coupled with an electric generator. The generators are solely suitable for land use, outdoors as well as indoors, in compliance with the environmental limits and those of the installation conditions stipulated by the manufacturer.

The generator must always be positioned according to the instructions found in the installation diagram provided by the manufacturer.

Any other use is strictly prohibited and can lead to safety hazards for the user and damage the generator.

The generator is built in compliance with the following EU Directives:

- **2006/42/EEC** Machinery directive.
- **2006/95/EC** Low voltage directive.
- **2004/108/EC** Electromagnetic compatibility directive.
- **2000/14/EC** Environmental noise emission by machinery and equipment intended for outdoor use.

In order to help the planning phase, EU standards harmonised with the EU Directives and/or international product standards may have been applied, particularly:

- **EN 12601** Reciprocating internal combustion engine driven generating sets – Safety.
- **ISO 8528** Reciprocating internal combustion engine driven alternating current generating sets.

3.2 Reasonably foreseeable misuse



DANGER

Improper use of the generator is extremely hazardous. The manufacturer declines any liability for any damage to people, objects and/or animal deriving from improper use of the generator.

Reasonably foreseeable misuse refers to any use other than that intended (for which the generator has been designed), carried out with methods other than those intended or specifically forbidden in the manual.

The following cases of evident product misuse can be indicated beforehand based on the manufacturer's experience:

- **It is FORBIDDEN** to activate the generator in closed areas without making sure there is adequate ventilation; when installed indoors, it is mandatory to expel the exhaust gases deriving from combustion outside the rooms where the generator is installed or at a safe distance from where it operates and/or the user is, by means of ducts or other suitable devices for this purpose.
- **It is FORBIDDEN** to use the generator on tilted surfaces that could block the flows of oil and fuel required for operation.
- **It is FORBIDDEN** to use the OPEN SET type of generator outdoors without having set up adequate protection against atmospheric agents such as water, snow and frost. If used outdoors, the environmental limits stipulated by the manufacturer must be complied with.
- **It is FORBIDDEN** to use the generator in environments classified according to the EU ATEX Directive 1999/92/EC, where an explosive atmosphere is likely to be formed or lasts for brief or long periods during regular operation.
- **It is FORBIDDEN** to use the generator to warm up an environment by means of the heat radiated from the engine.
- **It is FORBIDDEN** to use the generator when faults or malfunctions are noted.
- **It is FORBIDDEN** to allow people who have not reached the minimum age applicable by law in the respective countries of use to use and service the generator and who have not been previously informed and trained on the residual risks posed while working on the generator.
- **It is FORBIDDEN** to allow people to use and service the generator before having read and understood the instructions provided in the manual.
- **It is FORBIDDEN** to carry out installation, use and servicing operations for which information has not been provided by the manufacturer.
- **It is FORBIDDEN** to carry out installation, use and servicing operations if the instructions provided by the manufacturer are difficult to be understood.
- **It is FORBIDDEN** to carry out installation, use and servicing operations differently from that described in the manual.
- **It is FORBIDDEN** to carry out installation, use and servicing operations that are specifically prohibited in the manual.
- **It is FORBIDDEN** to refuel and perform maintenance while the generator is ON or on surfaces that are not flat.
- **It is FORBIDDEN** to refuel immediately after switching off the generator, when the engine is still hot; wait for the engine to cool down before refuelling and make sure that it is on a perfectly level surface.
- **It is FORBIDDEN** to remove the loads from the 63A and over sockets before having disconnected them by opening the corresponding switches.

- **It is FORBIDDEN** to apply electric loads whose power, voltage and/or current exceeds the maximum nominal specifications of the generator. Comply with the technical specifications provided.
- **It is FORBIDDEN** bypass the guards or safety devices, even temporarily. The guards and safety devices can only be removed to perform maintenance by expert personnel and when the generator is OFF. Once maintenance is completed, all the guards and safety devices that have been removed must be refitted in their original position and their correct operation must always be verified.
- **It is FORBIDDEN** for people to come near the OPEN SET generator unless they are assigned to use and service it.
- **It is FORBIDDEN** to use the SOUNDPROOF generator when the hood is totally or partially removed or if the doors are open.

	DANGER
<p>Using the SOUNDPROOF generator with the bonnet fully or partially removed or with the doors open is extremely dangerous and can cause serious burns and/or injuries due to contact with internal parts of the generator. It is prohibited to approach the engine suction zone with long loose hair or baggy clothing.</p>	

3.3 Use of personal protective equipment (PPE)

The type of personal protective equipment (PPE) and their use in the European Community is governed by the EU Directive 89/686/EEC and 89/656/EEC and subsequent amendments.

Specific personal protective equipment (PPE) may be required for certain operations. In this case, pictograms are found on the generator and/or in the manual, and their meaning is described in the following table.

Pictogram	Description
	Obligated to always wear protective gloves if the operations pose generic mechanical risks (e.g. crushing or shearing).



Pictogram	Description
	Obligated to wear hearing protection devices in accordance with the noise risk assessment of the relative work environment and legislation in force in the country of use.





3.4 Safety and warning signs

There are adhesive labels on the generator indicating safety and warning signals, and their meaning is described in the following table.

	DANGER
<p>It is forbidden to remove the warning labels that have a safety function. Failure to comply with this regulation shall render the warranty null and void and result in the buyer bearing full responsibility.</p>	

Description	Precaution
	<ul style="list-style-type: none"> • Pay attention to the areas close to the alternator and electrical connection points. • Keep a safe distance so as to prevent hazards deriving from direct or indirect contact being made with live parts or equipment. • Comply with the safety regulations and use the relative PPE when carrying out operations (protective gloves against electrical hazards). • Implement the connections of the cables with the generator OFF. • Perform maintenance on the electrical parts with the generator OFF and after having verified there is no voltage residue. • Do not use water if the generator catches fire.
<p>Electrical hazard deriving from the presence of live parts.</p> <p>The generator supplies power when it is ON, therefore be very careful not to come in contact with parts of the electrical system.</p>	

Description	Precaution
 <p>Hazards deriving from contact being made with hot parts.</p> <p>The engine and the silencer become hot during use and remain so for over an hour after being switched off.</p>	<ul style="list-style-type: none"> Do not touch the hot parts when the generator is ON and for at least one hour after being switched off. Wait for the hot parts to cool down before performing maintenance.
 <p>Risk of fire.</p> <p>Fuel is highly flammable.</p>	<ul style="list-style-type: none"> It is FORBIDDEN to smoke or use naked flames near the tank and fuel when refuelling. Refuel in a well ventilated area and always dry any fuel leak before starting the engine.
 <p>Hazards deriving from inhalation of toxic and harmful substances.</p> <p>Fumes containing poisonous substances are emitted from the silencer into the air while the generator engine is ON.</p> <p>The fumes contain substances that are harmful for the health, such as nitrogen oxides, carbon monoxide, unburned hydrocarbons, etc.</p>	<ul style="list-style-type: none"> Use the generator in well ventilated environments to disperse the fumes. If used in closed environments, convey the fumes outside by following the instructions provided in the installation diagram. Do not stop near the silencer and do not breathe in the emitted fumes.
 <p>Hazards deriving from keeping the engine ON during operation.</p>	<ul style="list-style-type: none"> Switch the engine OFF before refuelling the generator. Refuel only with the engine OFF. Make sure that the generator is in a horizontal position.

Description	Precaution
 <p>Fuel used DIESEL.</p>	<ul style="list-style-type: none"> Only use diesel. Choose the fuel according to the outdoor temperature. Use winter type of diesel for temperatures below 0 °C and as low as -20 °C.
 <p>Generic hazard.</p> <p>Various risks described in the instruction manual.</p>	<ul style="list-style-type: none"> Pay attention to all the safety precautions and warnings as well as to the information regarding the intended use and reasonably foreseeable misuse described in this manual.
 <p>Always refer to the instruction manual.</p> <p>The complete instructions to use and service the generator are present in the use and maintenance manual.</p>	<ul style="list-style-type: none"> Read and understand the instructions provided in the instruction manual. If the instructions are missing or not clear, always contact the manufacturer before operating on the generator. Always keep the use and maintenance manual near the generator, in place that is known and accessible to all the users.
 <p>Sound power level (L_{WA}) measured in compliance with the Noise Directive 2000/14/EC.</p>	<ul style="list-style-type: none"> Wear individual hearing protective devices (PPE) according to the noise risk assessment of the relative work environment and in accordance with the legislation in force in the country of use.
<p>When the generator is ON, it can cause damage to the auditory system if you stop near it for brief and long periods of time.</p>	

Description	Precaution
 <p data-bbox="121 376 424 439">Indication of a lifting anchor point.</p> <p data-bbox="121 465 424 564">Identify the devices and lifting anchor points on the generator.</p>	<ul data-bbox="432 215 734 398" style="list-style-type: none"> • Read and understand the lifting instructions provided in the specific paragraph in this manual before proceeding with the lifting operations.

3.5 Airborne noise emission

The generators are subject to tests to detect the sound pressure level of the A-weighted emission in compliance with that stipulated by the Machinery Directive 2006/42/EC.

The sound power value **L_{WA}** in generators marketed within the European Community is measured in compliance with the EU Directive 2000/14/EC and indicated on a special plate on the generator itself and in the CE Declaration of Conformity.

4 INSTALLATION

4 INSTALLATION	15
4.1 Transport and positioning	16
4.1.1 Lifting the generator with adjustable chains	16
4.1.2 Lifting the generator with a forklift	19
4.1.3 Transport and storage	20
4.1.4 Positioning	21
4.2 Connecting the utilities	21
4.2.1 Cable dimensions	21
4.2.2 Cable arrangement	21
4.2.3 Earthing the masses	22
4.2.4 Implementing the electrical connections	22
4.3 Connections for the automatic start up of the generator	25
4.4 Commissioning operations	25
4.4.1 Visual checks	25
4.4.2 Checking the engine oil level	25
4.4.3 First fuel fill-up	25
4.4.4 Connecting the battery cables	25
4.5 Start up operations after a long idle period	26

4.1 Transport and positioning



WARNING

The following lifting, transport and positioning operations must only be carried out by specialised personnel.

Always position the generator on a flat, smooth and level surface.

- Move away and gradually lift the generator, verifying that it is balanced with respect to the centre of gravity. Otherwise, lower the load until it rests on the floor of the transport vehicle and adjust the length of the chains according to the centre of gravity.

OPEN SET: 3 lifting points

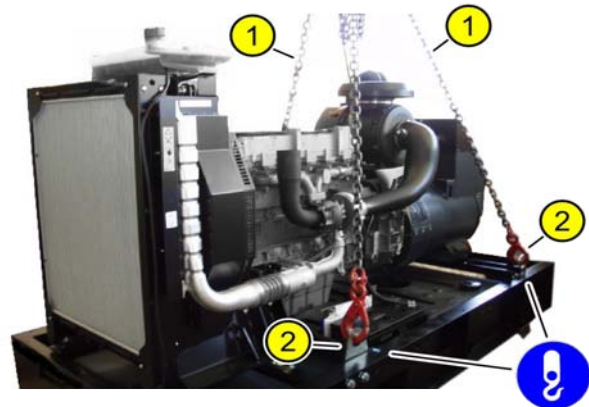

NOTE

The lifting and transport procedures describe the procedures implemented by the manufacturer when the generator is shipped from the factory. This information is provided in this manual for when the generator must be lifted and transported to the place where it will be installed the first time or if it is transferred to a different place.



NOTE

It is mandatory to use all three lifting points (2) set up on the base on the control side and on the opposite side. The lifting hook must be positioned as close as possible to the centre of the generator's lifting points to keep it from swaying when lifted. Adjust the length of the lifting chains (1) to balance the load, to reduce its stress and so that none of the chains can come into contact with the components while the generator is being moved.



NOTE

The generator must be handled with adequate lifting means for the mass to be lifted and the environment in which it is lifted. The exact weight of the generator is shown on the identification plate (see the "identification plate" paragraph).

4.1.1 Lifting the generator with adjustable chains

Proceed as follows to lift the generator with adjustable chains:

- Hook the lifting chains (1) in the relative anchor points (2) set up on the generator. The lifting anchor point is indicated on the machine by the relative information sticker.

OPEN SET: 4 lifting points

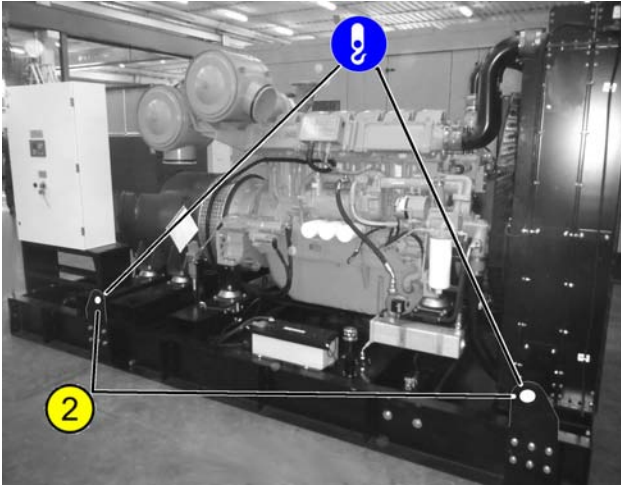

SOUNDPROOF: 1 lifting point

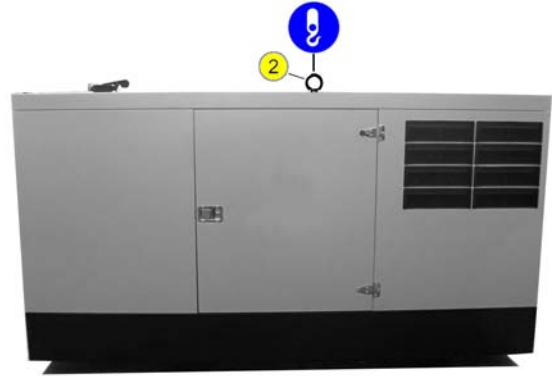

NOTE

It is mandatory to use all four lifting points (2) set up on the base on the control side and on the opposite side. The main lifting hook must be used together with a rocker arm (like when lifting “SOUNDPROOF with EFT” identified with the number (1)), which keeps the lifting chains at a distance to prevent them from coming into contact with the generator. Adjust the length of the lifting chains in order to balance the load and to minimise the angle between them (chains as vertical as possible).



NOTE

It is mandatory to use the preset lifting points (2) on the roof. The lifting hook must be positioned as close as possible to the vertical of the generator's lifting ring to keep it from swaying when lifted.

SOUNDPROOF: 2 lifting points

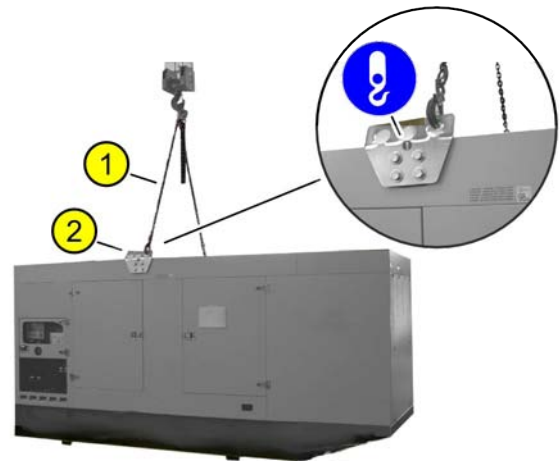



NOTE

It is mandatory to use both lifting points (2) set up on the roof from the control side and on the opposite side. The brackets set up on the lifting points are provided with 3 holes used to find the centre of gravity. The lifting hook must be positioned as close to the centre of the generator's lifting points as possible to keep it from swaying when lifted. The length of the 2 lifting chains (1) must form an angle of approximately 40° between the 2 chains: this limits the stress on the lifting elements.

STANDARD SOUNDPROOF: 4 lifting points

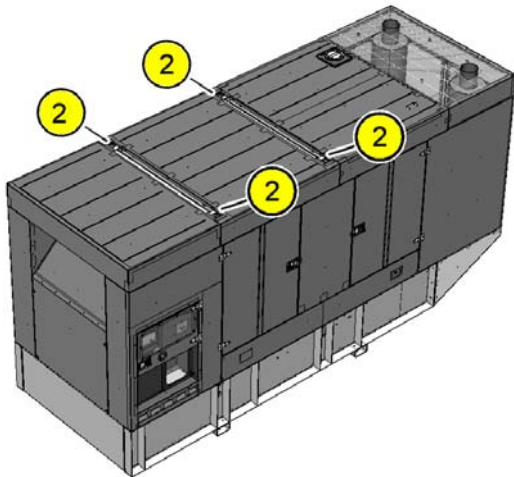

Detail of the position of the lifting points below:

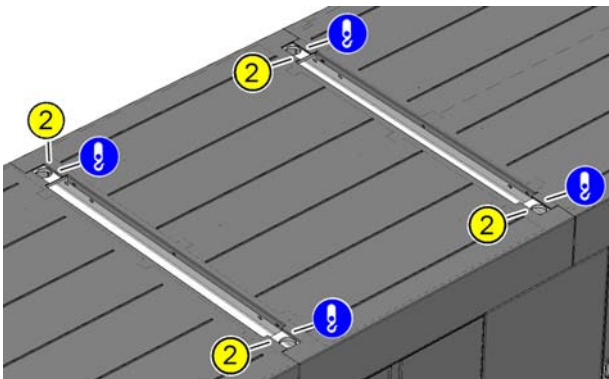

NOTE

It is mandatory to use all 4 lifting points (2) set up on the roof: 2 from the controls side and the other 2 on the opposite side. The main lifting hook (3) must be positioned as close to the centre of the generator's four lifting points as possible to keep it from swaying when lifted. If necessary, adjust the length of the lifting chains to balance the load. The length of the 4 lifting chains (1) must form an angle of approximately 40° between the 2 chains: this limits the stress on the lifting elements.

SOUNDPROOF with "EFT" (Extended Fuel Tank): 4 lifting points

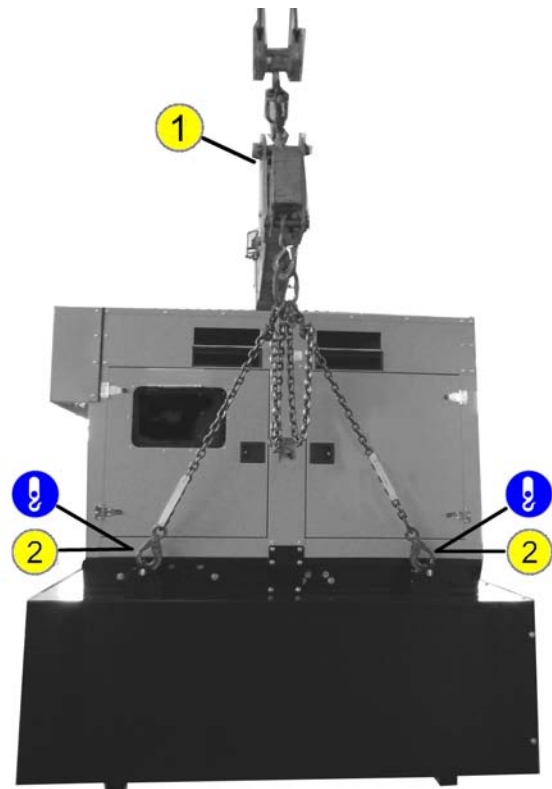



NOTE

It is mandatory to use all 4 lifting points (2) set up on the oversized tank: 2 from the controls side and 2 on the opposite side. The main lifting hook (1) must be used together with a rocker arm (1), which keeps the lifting chains at a distance to prevent them from coming into contact with the generator. Adjust the length of the lifting chains in order to balance the load and to minimise the angle between them (chains as vertical as possible).

4.1.2 Lifting the generator with a forklift



NOTE

Machines with NO lifting rings can ONLY be lifted by means of a forklift. In such instances, it is PROHIBITED to lift the machine in any other way.

Proceed as follows to lift the generator with a forklift:

- Insert the forks of the forklift (1) under the base of the generator (2), in line with the centre of gravity.
- Make sure that the forks of the lifter support the generator along its width as explained in the figure (3).
- Gradually lift the generator, verifying that it is balanced with respect to the centre of gravity. Otherwise, lower the load until it rests on the floor of the transport vehicle and adjust the position of the forks according to the centre of gravity.

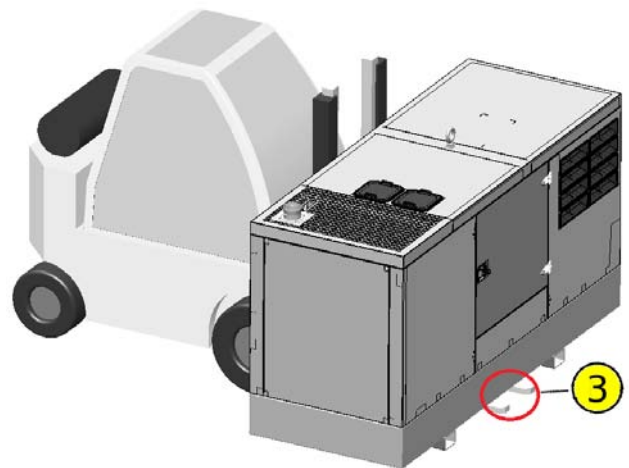
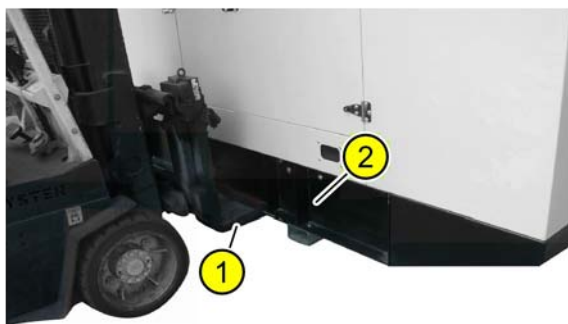

4.1.3 Transport and storage

Proceed as follows when transporting the generator:

- The generator can ONLY be transported with fuel on vehicles that are approved and certified to transport equipment containing fuel. Otherwise, empty the fuel tank completely before transporting the generator.
- Block the generator securely on the transport vehicle with devices that are suitable for the purpose, so as to avoid it moving or tipping over while the vehicle moves.
- When transporting the OPEN series generator on an open vehicle, do not leave the generator exposed to direct sunlight or the weather for long periods of time. Protect it with sheets or other adequate material.
- When transporting the generator on a closed vehicle, the temperatures inside the load compartment could cause the liquids to evaporate, thereby posing a risk of fire and explosion. Empty the fuel tank IF the vehicle is not approved and certified to transport fuel.



NOTE

If the generator is to be stored for a long time after being transported (over 30 days), follow the guidelines provided in the “Placing out of service for long periods” paragraph).

4.1.4 Positioning

Refer to the installation diagram supplied with the generator to learn how to position it.

4.2 Connecting the utilities



WARNING

The electrical connections must only be carried out by specialised personnel.



WARNING

The following requirements for use must be complied with to prevent risks posed for persons and damage caused to the generator :

- Do not connect utilities to the generator unless the electrical features are known or if these are different from those of the generator (e.g. different voltages and/or frequencies).
- The total absorption of all the equipment connected simultaneously must be considered.
- All the generators are equipped with protections against over-current, over-voltage and short-circuit. In any case, do not intentionally connect loads with maximum currents that exceed the specifications of the sockets they are connected to.
- Do not connect a number of generators in parallel unless equipped with the special parallel board.



NOTE

All the connection operations of the utilities must be carried out in compliance with the guidelines provided on the wiring diagrams.

4.2.1 Cable dimensions

- The installer is responsible for the selection and sizing of the cables who installs the system. Cables with an inadequate section cause excessive drops in voltage and the cable to reach hazardous temperatures.

4.2.2 Cable arrangement

- The set of cables used to connect the generator-utility must be duly set up in a suitable channel or passage, protected from making contact or being crushed.

4.2.3 Earthing the masses



NOTE

The sizing of the connection cable to the earth plate and the relative contact resistance must be compliant with the regulations and laws in force in the country in which the generator is used.

Do not connect the generator to any cable/terminal if the electrical specifications are unknown. Refer to the specifications of the generator to calculate the correct electrical load.

The generator is set up to connect the masses to the earth. The connection of the protective conductor to the main earth collector or the plate, found in the place of use, must be set up by the installer who must use a yellow/green cable of adequate section for this purpose.

The earth connection found in the electric panel of the generator is indicated by the following symbol.



4.2.4 Implementing the electrical connections

Depending on the type of the electric panel installed on the machine, there can be differences with respect to the images shown on these pages, even though not significant.

If any doubt should arise, do not hesitate to contact the generator supplier for clarification.

Connections to panel type (A):

- Remove the two fixing screws (1) and open the protection panel.
- Remove the plate (2), drill it and insert a cable gland suitable for the cross section of the cable used to connect the utility.
- Pass the cables through the specific openings (3) made on the panels.

ATTENTION: When choosing the cable, consider that the openings (3) are approximately 60 mm high.

- Connect the cable to the specific terminals (4) following the indications on the wiring diagrams supplied with the generator.
- Fix the plate (2) then close the protective panel and tighten the two fixing screws (1).

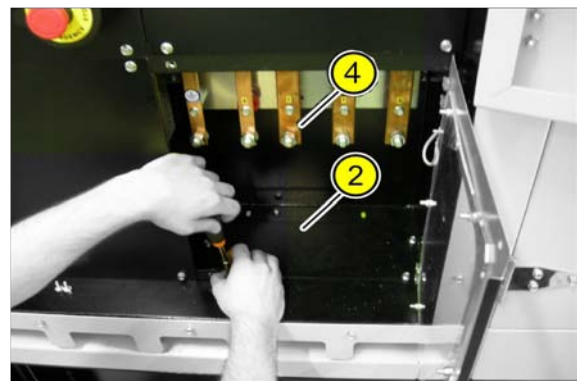
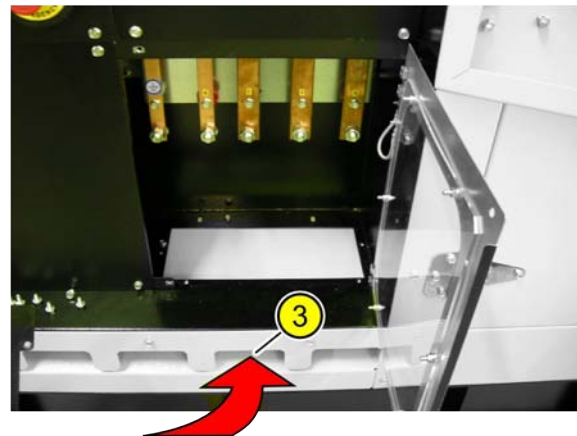

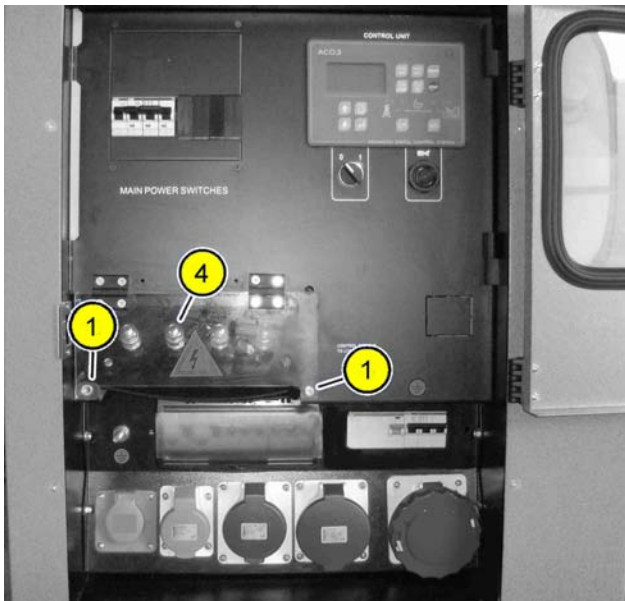

- Connect the cables to the specific terminals (4) following the indications on the wiring diagrams supplied with the generator.
- Close the protection panel and tighten the two fixing screws (1).

Connections to panel type (D):

- Remove the two fixing screws (1) using the appropriate spanner and open the protection panel (2).
- Pass the cables through the bottom side of the panel through the specific opening positioned underneath the electric panel (3).

Connections to panel type (B):

(Referring to previous image)

- Remove the two fixing screws (1) and open the protection panel.
- Pass the cables through the bottom side of the panel.
- Connect the cable to the specific terminals (4) following the indications on the wiring diagrams supplied with the generator.
- Close the protection panel and tighten the two fixing screws (1).



Connections to panel type (C):

- Remove the two fixing screws (1) and open the protection panel (2).
- Pass the cables through the bottom side of the panel, blocking them with the specific clip (3).

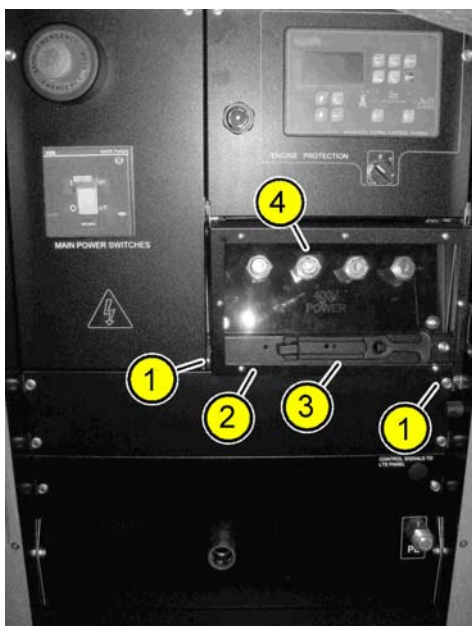
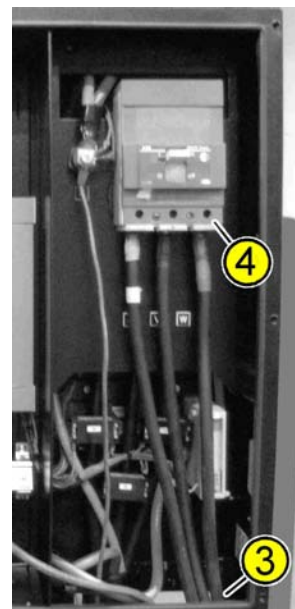

- Connect the cables to the specific terminals (4) following the indications on the wiring diagrams supplied with the generator.
- Close the protection panel (2) and tighten the two fixing screws (1) with the specific spanner.

Connections to panel type (E):

In some generator models the electric control part could be installed separately from the power part. In this case, there will be 2 different electric panels: the "control board" and the "power board", which will normally be positioned on the two opposite sides of the base near the power alternator.

Control board:



Closed power board:

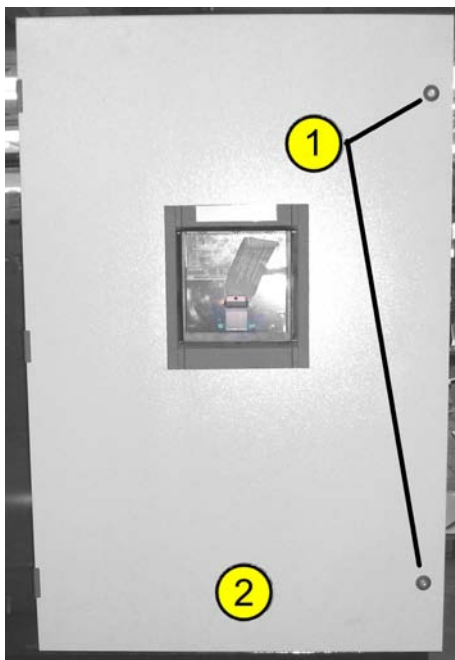

- Remove the two fixing screws (1) using the appropriate spanner and open the protection panel (2).

- Pass the cables through the bottom side of the panel through the specific opening positioned underneath the electric panel (3).
- Connect the cables to the specific terminals (4) following the indications on the wiring diagrams supplied with the generator.
- Close the protection panel (2) and tighten the two fixing screws (1) with the specific spanner.

Open power board:

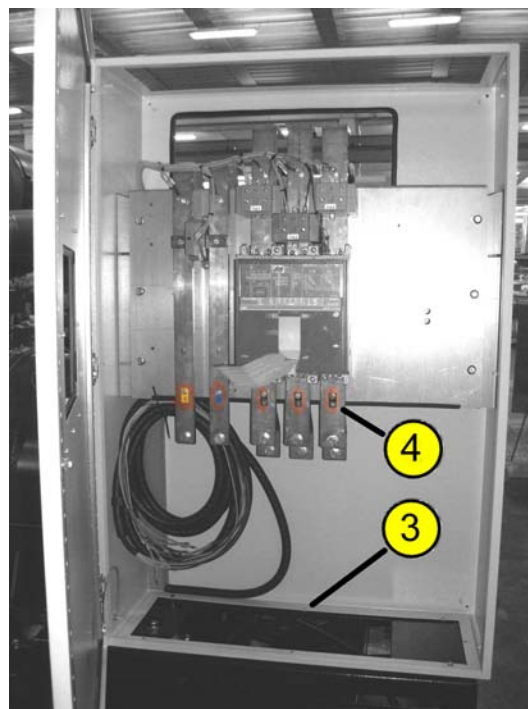

4.3 Connections for the automatic start up of the generator



WARNING

The electrical connections must only be carried out by specialised personnel.



NOTE

All the connection operations of the utilities must be carried out in compliance with the guidelines provided on the wiring diagrams.

Connect the cable on which the network or the remote start-up and stop signal is to be monitored so as to allow the generator's automatic start-up. Only the wiring diagram supplied with the generator is to be referred to for the connection of these signals.

4.4 Commissioning operations

The operations described in the following paragraphs must be carried out before proceeding with the commissioning of the engine.

4.4.1 Visual checks

- Verify that the generator has not been damaged during transport.
- Verify that no parts of the generator have been disassembled, such as the protections, the air filter, the tank cap, etc. Otherwise, restore the optimal conditions.

4.4.2 Checking the engine oil level

- Generally, the generator is shipped with oil in the engine; however, check the level, according to the instructions provided in the "Inspecting and topping-up the oil" paragraph.



WARNING

Running the engine without oil or with oil below the minimum level will seriously damage it.

4.4.3 First fuel fill-up

- The generator is shipped without fuel and the tank must be filled before start-up.
- Fill the fuel tank up to 60% of its capacity according to the instructions provided in the "Refuelling" paragraph with the generator positioned on a perfectly horizontal surface.
- It is recommended to also fill the diesel intake circuit through the special pump. Further information can be found in the engine manual.

4.4.4 Connecting the battery cables

- The battery is shipped by the manufacturer charged and ready for use.
- Verify that it has not been damaged during transport. There must be no signs of impact or acid leaks. Otherwise, replace the battery.
- Connect the red cable (1) to the positive pole of the battery (2).



NOTE

If necessary, disconnect the battery - always disconnect the negative pole (2) first and then the positive pole (3).

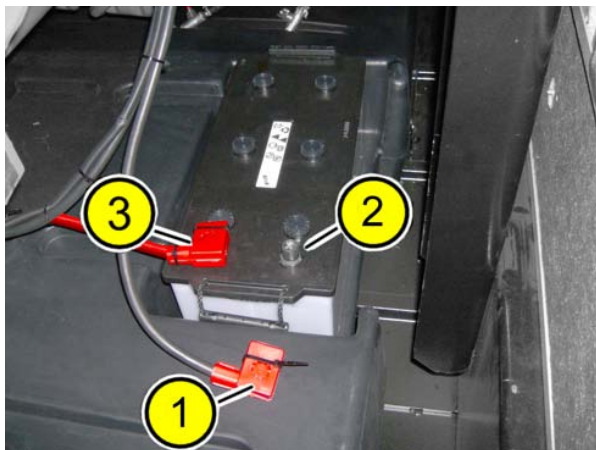

4.5 Start up operations after a long idle period



WARNING

The operations described below must only be carried out by specialised personnel.

The following operations require an in-depth knowledge of certain parts of the engine. See the manufacturer's documentation of the engine for further information or if necessary, refer to specialised personnel.



NOTE

Oil preservatives are marketed by oil companies. Refer to the manual of the engine or contact the manufacturer of the engine to learn the type.

Verify that all the windings of the alternator are isolated before activating the generator after a long idle period. If incorrect isolation values are detected, it is recommended to consult the nearest PRAMAC assistance centre.

Follow the specific guidelines provided in the manuals of the relative manufacturers, according to the type of engine, in order to carry out the restart operations correctly. The main operations that must be carried out are:

- Remove any covers from the engine, air filter and drain pipe.
- If necessary, top-up the lubricant as recommended by the manufacturer of the engine. Unless done previously, replace the oil filters.
- Fit the new fuel filters and bleed the system.
- Check the transmission belt/s.
- Check the condition of all the sleeves and tighten the clamps.
- Close the drain valves and fit any caps.
- Check the level of the coolant. Top-up, if necessary.
- Connect the batteries after having charged them completely.
- Start the engine and let it warm up on minimum before loading it.
- Check that there is no oil, fuel or coolant leak.

5 USE

5 USE	26
5.1 Safety precautions for use	27
5.2 Preliminary checks for use	27
5.3 Generator control panel	28
5.4 Electronic control board commands	30
5.5 Starting up the generator	31
5.6 Stopping the generator	32
5.7 Emergency stop of the generator	33
5.8 Manual refuelling	33
5.9 Using the generator at high altitudes or high ambient temperatures	35

5.1 Safety precautions for use



WARNING

Failure to comply with the instructions for use and precautions could cause serious injuries or death. Always follow the procedures and precautions indicated in this manual



WARNING

The generator can only be used by qualified personnel.

The following are the main safety precautions which the user must comply with. However, since it is impossible to include all the dangers which can arise when using the generator, remember that the decision whether or not to perform an operation is strictly personal.

Comply with the following precautions when using the generator:

- Before operating on the generator, read and understand the contents of this manual.
- Comply with the warnings affixed near the danger zones.
- Use clothing suitable for the task to be carried out, without any loose fitting parts or accessories which can get hooked, to avoid the risk of entanglement and dragging.
- Always wear personal protective equipment (PPE), when necessary, in accordance with the specific indications in the manual and legislation in force in the country of use.
- Before carrying out any operation near the generator, remove watches, bracelets, rings and chains and tie or gather long hair in a net.
- Use suitable hearing protection devices (protective plugs or earmuffs) in the presence of loud noise, in accordance with the noise risk assessment of the relative work environment and legislation in force in the country of use.

- Check the efficiency of all generator protections and safety devices daily and before use.
- Do not operate if the protections and/or safety devices have been removed.
- Do not intentionally bypass protections and safety devices. Preserve the characteristics of the generator by avoiding to implement modifications, altering the functionality and tampering with protections or safety devices.
- Do not use the generator in the presence of malfunctions or persistent faulty conditions.

5.2 Preliminary checks for use

- Perform a visual check around and underneath the engine looking for traces of oil or fuel leakage. If needed, resolve the problem and dry the engine well before starting it.
- Remove any slag or filth in excess, especially around the silencer.
- Make sure that all protections and covers are in place and that all nuts, bolts and screws are tightened.
- Check the fuel level and top-up if necessary (see the "refuelling" paragraph). Starting the engine with a full tank helps to eliminate or reduce work interruptions for refuelling.
- Check the engine oil level (see the "checking and changing the engine oil" paragraph). The engine could be damaged if used with a low oil level.
- Check the coolant level (see the "checking the coolant level and topping up" paragraph). The engine could be damaged if used with the coolant level lower than the minimum.
- Check the air filtering element (refer to the engine manual for details): a dirty air filtering element limits the air flow, thereby reducing engine performance.
- Do not connect all the single phase loads on the same phase. They must be distributed to avoid damaging the alternator: do not apply a single phase load with >40% power of the generated rated power on a single phase. This helps keep a balance between the current circulating on the three phases within approximately 33%, thereby reducing the voltage drop on the phase with the higher load within approximately 5%.

5.3 Generator control panel

Automatic panel with standard electronic board:

The commands are located on the same control panel from where the various work parameters can be changed and/or the generator controlled. The following figure summarises in detail the commands present on the automatic panel with electronic board.

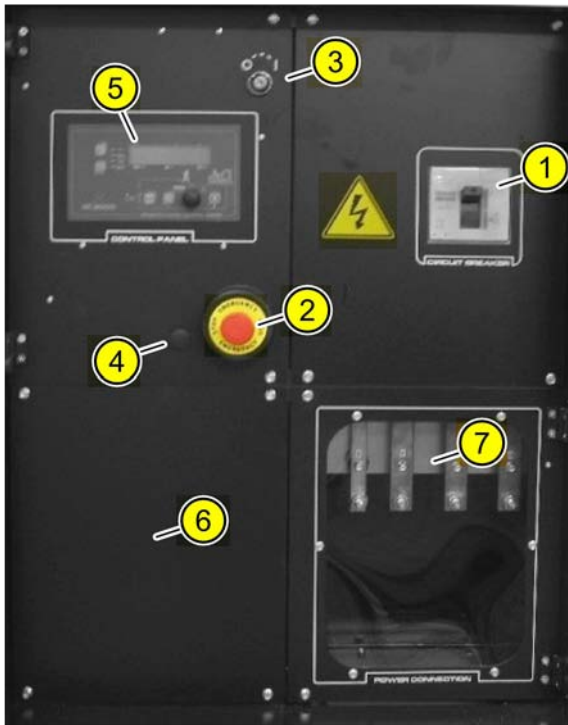

CP. #	Description
1	Main switch or disconnecting device.
2	Emergency button.
3	Control panel power selector (ON/OFF).
4	The following controls can be present, depending on the type of model: <ul style="list-style-type: none"> • Socket for the exclusive use of the manufacturer's technical personnel. • Reset button (present only when the ADI supplement is installed).
5	Electronic control board.
6	Space reserved for the installation of the socket kit (optional) or connectors for parallel (see parallel board paragraph).
7	Utilities connection box.

NOTE: in the following paragraphs, the controls can be identified as in this example: "Emergency button (CP.2)".



NOTE

General guidelines concerning the various types of control boards are provided here. Refer to, read and understand the use and maintenance manual of the specific electronic boards and the supplied wiring diagrams.

Automatic panel with electronic board parallel to the mains or between several generators:

Even in this type of board the commands are located on the same control panel from where the various work parameters can be changed and/or the generator controlled. The previous figure summarises in detail the commands present on the automatic panel with electronic board.

If the board is preset to place several generators in parallel, the specific space (CP. 6) also has the following connectors:

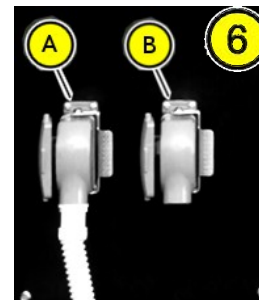

There can be several parallel combinations. Therefore, only the most common ones are illustrated here. Refer to the manual of the specific electronic board (supplied) for details of special cases.



NOTE

After having read and understood the following general guidelines, always refer to the supplied wiring diagram of the generator to complete the installation.

- a) Generator (G) directly connected to the LOAD, in an island network, with manual or remote start up. In this case, refer to the previous paragraph. Below is an example block diagram:

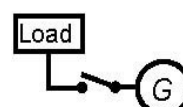

b) Generators (G) connected in parallel, in an island network, powering a LOAD. In this case, the board is equipped with parallel connectors. Below is an example block diagram:

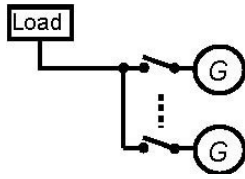

If the case falls under this configuration, refer to the following verification inside the control panel:

- With the generator off (see specific paragraph), disconnect the power to the board (selector CP. 3 in figure).
- Connect the signal and power cables appropriately inside the control panel referring to the wiring diagram supplied with the generator.

c) Generator (G) connected in parallel with the electric mains with which a LOAD is powered in parallel to the generator. In this case as well the board is equipped with parallel connectors. Below is an example block diagram:

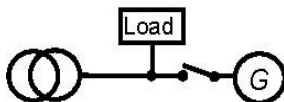

If the case falls under this configuration, refer to the following verification inside the control panel:

- With the generator off (see specific paragraph), disconnect the power to the board (selector CP. 3 in figure).
- Connect the signal and power cables appropriately inside the control panel referring to the wiring diagram supplied with the generator.

Normally, unless agreed otherwise, the generators are supplied set up for a parallel in the island network between 2 machines (reference to case b): connector "A" in the previous figure is supplied with a cable to connect the 1st generator with the 2nd, while connector "B" is equipped with a cover terminal (to inform the electronic board that there are no other machines connected in parallel).

More in general, when there are several generators in parallel, the cover terminal (in position "B" in the figure) is only required on the first and last generator of the parallel sequence.



NOTE

General guidelines concerning the various types of control boards are provided here. Refer to, read and understand the use and maintenance manual of the specific electronic boards and wiring diagrams supplied.

Automatic panel with electronic control board, separate from the power board:



NOTE

After having read and understood the following general guidelines, always refer to the supplied wiring diagram of the generator to complete the installation.

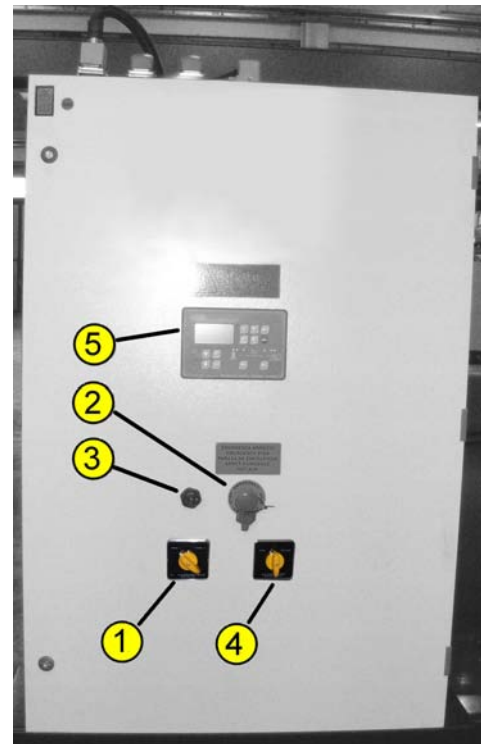

CP. #	Description
1	Switch with double fuel loading pump (optional).
2	Emergency button.
3	Acoustic alarm signal emitter for faults detected by the electronic control board.
4	Switch with optional double starting system.

CP. #	Description
5	Electronic control board.



NOTE

General guidelines concerning the various types of control boards are provided here. Refer to, read and understand the use and maintenance manual of the specific electronic boards and wiring diagrams supplied.

Manual panel with digital board:

The panel in manual configuration is equipped with an electronic control board which displays alarms and operating states of the generator by means of LED signals (CP. 5 in following figure).

The figure shows the main parts of the manual panel:

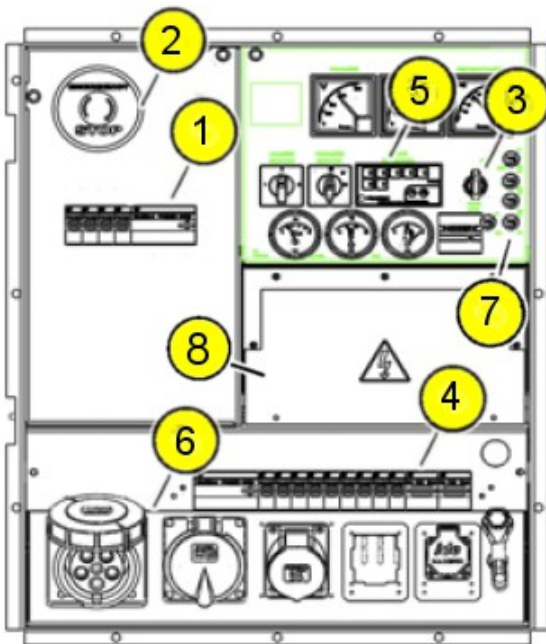

CP. #	Description
1	Main switch or disconnecting device.
2	Emergency button.
3	Control panel power ON/OFF key selector: <ul style="list-style-type: none"> • 1st click to the right to switch on panel and instruments (optional). • 2nd rotation to the right to start the generator. • Vertical key position to switch generator off.
4	Circuit breaker/differential switches for each electric socket of the panel.
5	Manual control board with indicator LEDs.
6	Space reserved for installation of socket kit (present in the image and optional).
7	Visible fuse kit (optional).
8	Load connection bars by means of cable (below protection panel indicated in the figure).



NOTE

General guidelines concerning the various types of control boards are provided here. Refer to, read and understand the use and maintenance manual of the specific electronic boards and wiring diagrams supplied.

5.4 Electronic control board commands

For further information, see the specific documentation of the electronic board attached to this manual.

5.5 Starting up the generator



NOTE

As a general rule, no generator must operate continuously below 30% - 35% of its rated capacity; this could cause excessive oil consumption and an accumulation of carbon deposits in the engine exhaust system, thereby damaging the engine permanently.



NOTE

If the generator is being started for the first time or after a long idle period, perform the operations described respectively in the "operations for commissioning" or "starting up operations after long idle period" paragraphs found in the installation chapter.



WARNING

After all the utilities have been connected properly, make sure there are no persons exposed to risks caused by switching the generator on and then proceed with the following steps.



WARNING

The generator connected and set up for automatic start-up can do so at any time when it detects a power failure.

Generators equipped with the *“Automatic panel with standard electronic board”* can be started:

- in manual mode *“MAN”* using the start and stop buttons on the control board ,
- automatically *“AUTO”*, when the generator is connected and set up to start when it detects a power failure.
- or automatically in *“TEST”* mode.

To start up in automatic mode *“AUTO”*, the connections described in the *“Connections for automatic start of generator”* paragraph must be implemented.

Refer to the supplied use and maintenance manual of the electronic board for details.

Generators equipped with the *“Manual panel with digital board”* can be started:

- in manual mode directly from the controls on the panel,
- remotely in manual mode by using the specific accessory (*remote start & stop*) for remote control of the generator,

Refer to the supplied use and maintenance manual of the digital board for details.

“Automatic panel with standard electronic board” manual starting:

- Make sure that the emergency button (**CP.2**) is not pressed.
- Set the main switch (**CP.1**) and main circuit breaker of the socket kit (where present) to OFF.
- Select manual mode *“MAN”* on the electronic control board.
- Proceed to start the generator as described in the supplied manual of the standard electronic board.
- Check that no operating faults are signalled and always refer to the supplied manual of the electronic board to correct faults before using the generator.
- Leave the generator run until it reaches ideal operating conditions (do not connect electric loads).
- Check the engine to make sure that there is no water, oil or fuel leakage.
- Make sure that the air intake valves of the alternator are not obstructed and that air can circulate freely around the radiator.
-

- After approximately 2-3 minutes of operation, check the frequency and voltage values; when they are stable, the main circuit breaker of the socket kit (where present) can be set to ON.
- Set the main switch (**CP.1**) to ON.
- Check that the generated voltage, frequency and current values are suitable for the connected utilities.

“Manual panel with digital board” manual start:

- Make sure that the emergency button (**CP.2**) is not pressed.
- Set the main switch (**CP.1**) and main circuit breaker of the socket kit (where present) to OFF.
- Insert the key in the key block.
- Turn the key clockwise until the 1st click (“ON” position). This powers the board and the control panel.
- Turn the key clockwise until another click (“START” position), holding it manually until the generator starts.
- When you release the key it returns automatically to “ON”.
- If the generator does not start up, make sure you have carried out all the required operations before starting and check whether any indicator light signalling faults is on. If a fault is present, correct it and try to restart by pressing the start button.
- Leave the generator run until it reaches ideal operating conditions (do not connect electric loads).
- Check the engine to make sure that there is no water, oil or fuel leakage.
- Make sure that the air intake valves of the alternator are not obstructed and that air can circulate freely around the radiator.
- After approximately 2-3 minutes of operation, check the frequency and voltage values; when they are stable, the main circuit breaker of the socket kit (where present) can be set to ON.
- Set the main switch (**CP.1**) to ON.
- Check that the generated voltage, frequency and current values are suitable for the connected utilities.

“Automatic panel with standard electronic board” automatic starting:

- Make sure that the emergency button (**CP.2**) is not pressed.
- Set the main switch (**CP.1**) and main circuit breaker of the socket kit (where present) to ON.
- Select the “**AUTO**” operating mode on the electronic control board. The generator will start automatically when it detects a power failure.
- Refer to the supplied manual of the standard electronic control board.

“Automatic panel with standard electronic board” test mode starting:

- Follow the guidelines to start in manual mode “**MAN**”, however, select the “**TEST**” mode on the control board.



WARNING

To check the proper operating conditions, it is recommended to start the generator at least once every 15 days without an electric load connected and once a month applying an electric load that is 50% of the rated power for about 30 minutes.

5.6 Stopping the generator

- Set the main switch (**CP.1**) to OFF. Leave the engine running for approximately 2-3 minutes to allow it to cool off.
 - In the case of “*Automatic panel with standard electronic board*”: follow the stopping instructions provided in the supplied manual of the electronic board.
- NOTE:** The “**OFF**” mode can be selected on the standard electronic control board to maintain the stop condition and prevent the generator from being started.
- In the case of “*Manual panel with digital board*”: turn the key selector (**CP.3**) to “**OFF**” and wait for the engine to stop completely.



WARNING

It is FORBIDDEN to disconnect loads from sockets that are 63A or greater before having completely switched the generator off.

5.7 Emergency stop of the generator

In this operating mode, press the emergency button (CP.2) to stop the generator quickly.



NOTE

Before switching the generator back on, you must identify and resolve the causes which required an emergency stop and then reset the button by turning it clockwise.



ATTENTION

Wait before you approach and/or intervene on the engine as it remains very hot even after being switched off. Allow the generator to have sufficient ventilation when stopped in order to cool off.

5.8 Manual refuelling



WARNING

During refuelling, the risk of fire persists due to the flammability of the fuels used. The following is **FORBIDDEN** during the entire operation:

- To use naked flames.
- To smoke.
- To refuel the generator with the engine running.



WARNING

During refuelling, there is the risk of the fuel coming in contact with skin or eyes or inhalation of fumes. Use the specific personal protective equipment (PPE) such as protective gloves and goggles, remain away from the filler hole of the tank and do not breathe in fumes.



NOTE

Choose fuel depending on the ambient temperature in which the generator is used. Purchase and use winter type of diesel oil for temperatures below 0 °C and as low as -20 °C.



NOTE

Always use the same type of fuel. Never mix different types of fuel such as different types of diesel oil.



NOTE

Do not pour fuel on the hot engine or on other parts of the generator. Remove fuel spills from painted surfaces with a rag. Be careful not to touch or hit hot parts of the engine. Never use fuels that are old or contaminated with other elements (e.g. water or oil). Prevent filth or water from entering the fuel tank.

- For the *“Automatic panel with standard electronic board”* the fuel level indication can be read on the screen of the electronic board itself. Refer to the supplied manual of the standard electronic board for details.
- In the case of *“Manual panel with digital board”*: check the fuel level inside the tank and make sure that the reserve indicator LED on the digital board is not on.
- Switch the generator engine off (see the “Stopping generator” paragraph).
- When refuelling with an external pipe, top up the fuel according to the relative type of refuelling system (e.g. open the external tank valve, etc.). The figures below show an example of windows or holes for the pipes (1) to be passed towards the external tank.



- If NO piping for external refuelling is set up, open the access doors to the engine (soundproof version), then unscrew and remove the fuel filler cap (2). When refuelling is finished, close the fuel filler cap and the access doors to the engine (soundproof version).

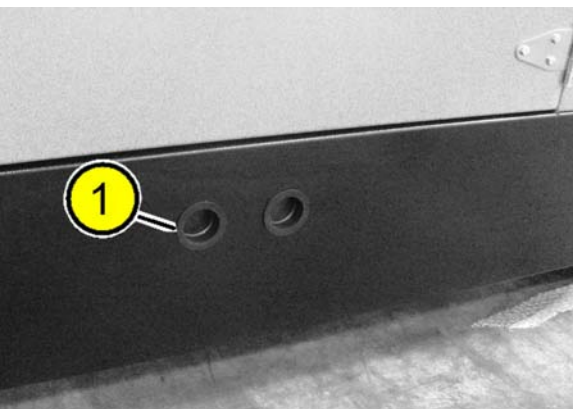
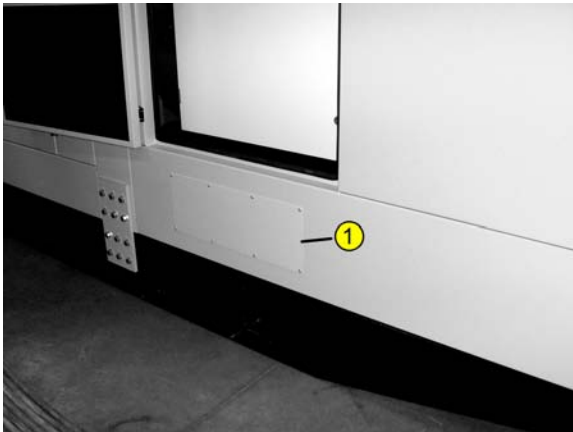

- Do NOT fill the tank over the maximum level by checking it on the specific page of the display of the electronic board for *“Automatic panel with standard electronic board”* or by inspecting it visually in the case of *“Manual panel with digital board”*.

5.9 Using the generator at high altitudes or high ambient temperatures



NOTE

Should it be necessary to perform modifications to adapt operation of the generator, always request the manufacturer's assistance.

It is FORBIDDEN to adjust engine parameters and/or to add additives to the fuel to enhance engine power over the limits recommended by the manufacturer.

As the altitude or ambient temperature increases, air density decreases. This rarefaction of the air has an adverse effect on engine operation, decreasing the maximum power, deteriorating the quality of the exhaust gas, increasing temperatures and in extreme cases, making it hard to start up.

If the actual environmental conditions are not specified when drafting the contract, the power of the generator is intended to refer to standard environmental conditions indicated in the technical data, as stipulated in the reference standard ISO8528-1.

If the actual environmental conditions should subsequently change, you must contact the manufacturer to calculate the new derating values and for the necessary calibrations (when possible).

6 MAINTENANCE

6 MAINTENANCE	36
6.1 Importance of maintenance	37
6.2 Safety precautions for maintenance	38
6.3 Electrical maintenance interventions	38
6.3.1 General checks on the electrical system	38
6.3.2 Checking the battery	39
6.4 Checking the alternator	39
6.5 Mechanical maintenance interventions	40
6.5.1 Checking and topping up the engine oil level	40
6.5.2 Changing the engine oil and filter	40
6.5.3 Verifying the coolant level and topping up	40
6.5.4 Replacing the coolant filter	41
6.5.5 Replacing the air filter	41
6.5.6 Replacing the fuel pre-filter and filter	42
6.5.7 Draining fuel from the tank	42
6.6 Maintenance schedule	43
6.6.1 Electrical system maintenance schedule	43
6.6.2 Maintenance schedule of the mechanical parts	43

6.1 Importance of maintenance

 **WARNING**

If maintenance is performed incorrectly or if a problem is not resolved before activating the generator, this could malfunction and cause serious or fatal injuries.

Always follow the recommendations and inspection and maintenance schedules provided in this manual. Check the state of the generator daily and immediately replace the worn or damaged parts. The following pages include a maintenance schedule, inspection and maintenance procedures that are to be performed with essential manual tools in order to help you take good care of the generator. Other maintenance activities that may be more complex or that require special tools are reserved for the manufacturer and therefore, not described in this manual. Always contact the manufacturer for this type of intervention.

 **NOTE**

Always refer to the manuals of the relative manufacturers of the components installed in the generator before performing maintenance (e.g. engine, alternator, etc.).

 **WARNING**

Failure to comply with the maintenance instructions and precautions could cause serious or fatal injuries. Always follow the procedures and precautions indicated in this manual. Do not perform maintenance that is not described in this manual; contact the manufacturer.

 **WARNING**

All the maintenance operations must only be carried out by specialised personnel.

The following are the main safety precautions which the user must comply with. However, since it is impossible to include all the dangers that could arise during maintenance, remember that the decision whether an operation is to be performed is strictly personal.

Comply with the following precautions when performing maintenance on the generator:

- Before operating on the generator, read and understand the contents of this manual.
- Learn and comply with the safety precautions for use of the generator (see the specific paragraph).
- Learn and comply with all the operations intended to set the generator in safety.
- Do not perform maintenance or lubrication with generator ON and with the disconnecting switch closed.
- Set the generator on a flat surface, disconnect all the utilities and switch the engine off before proceeding with any maintenance.
- Use adequate tools and any equipment to repair the generator.
- Remove all the tools used for maintenance and set them in their relative places before restarting the generator.
- Restore all the protections and safety devices possibly removed and verify they work properly before restarting the generator.
- Be very careful when handling the fuel so as to reduce the risk of fire or explosion.
- Only use non-flammable solvents and never gasoline to clean the components.
- Keep cigarettes, sparks and flames away from all the components that are related to fuel.

6.2 Safety precautions for maintenance



WARNING

Prevent risks of an electrical nature by disconnecting the power from the board before performing any maintenance by means of the specific key selector, isolating both the main disconnecting switch (CP.1) and the load disconnecting switch and disconnecting the battery.

6.3 Electrical maintenance interventions



DANGER

Verify there are no residual voltages before disassembling a device or making contact with parts of it. Pay particular attention when working on circuits connected to capacitive loads (capacitors) or on external connections of which you are not sure of their isolation.



NOTE

Pay attention when handling electronic circuits. Many components are subject to being damaged or broken by electrostatic charges and therefore, also from contact made with the human body. Touch an isolated metal structure to discharge your potential charge before working on the component.



NOTE

Do not use compressed air to remove the dust during the cleaning operations of the electrical system. Blowing compressed air inside the panel can cause the components to break and the conductors to loosen from their clamps.

6.3.1 General checks on the electrical system

Verify there is no water or condensation infiltration

- Make sure there is absolutely no water infiltration or the formation of hazardous condensation.
- Promptly check the sealing systems (gaskets).
- Immediately remove water and perform the necessary repairs.

Verify the tightness of the cables and components

- Check the tightness of the power cables and connection bars.
- Check the tightness of the clamps and wires on the terminal boards by pulling the cables lightly.
- Check the tightness of all the fixing screws of the components, both in the control board and on the generator.
- Tighten the screws when necessary.

Internal cleaning of the electric boards and control panel

- Use a vacuum cleaner to remove dust from inside the electric board.

Visually check the condition of the equipment and devices

- Verify the good condition of the equipment and devices inside the board, on the control panel and on the generator.

Check the condition and/or replace the electric wires

- Check the state of the electric wires and replace them if their ideal flexibility and insulation conditions are altered.
- Pay particular attention when checking electric wires in adverse environments (e.g. in high or cold temperatures, humidity).
- When necessary, replace the electric wires while referring to the wiring diagrams.
- Check the condition of the power cables and connectors. Make sure there is no contact with electric parts.

6.3.2 Checking the battery

It is recommended to check the battery poles (2 and 3) and the electrolyte level every 15 days.

If the poles (2 and 3) show signs of corrosion, remove it using ammonium diluted with water and a hard brush.

Once the corrosion has been removed and the terminals reconnected, lubricate the poles with suitable grease.

If the generator remains idle for a long time (more than 30 days), disconnect the poles of the battery to keep it from discharging. Always disconnect the negative pole (2) first and then the positive pole (3).

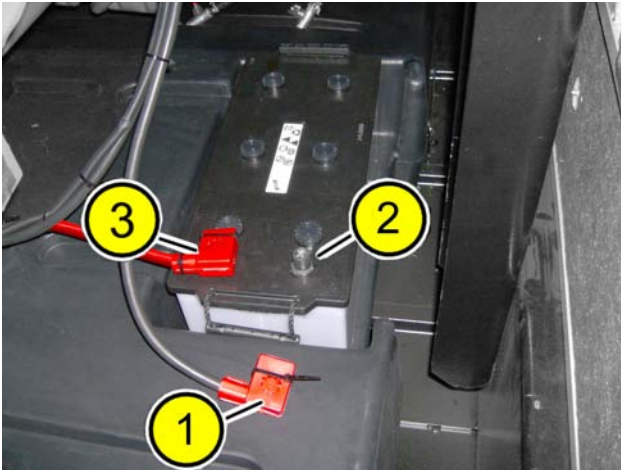

6.4 Checking the alternator

Checking the connections:

Make sure that the electric connection cables are firmly fixed to the connection terminals; tighten the screws if necessary.

Checking the windings:

The condition of the windings can be determined by measuring the earth insulation resistance.



NOTE

It is mandatory to refer to the documentation of the manufacturer of the alternator to implement the necessary connections to carry out the above-mentioned measurement and to know the resistance values that are to be checked. Should the resistance value of the windings be incorrect, have it repaired as required by the manufacturer of the device.

Checking the bearings and alternator maintenance:

Refer to the supplied alternator manual before performing any operation on the alternator.

6.5 Mechanical maintenance interventions

6.5.1 Checking and topping up the engine oil level



ATTENTION

The oil must be checked while the engine is still hot. Pay attention to contact with hot parts and squirting of hot oil which could cause burns.

Refer to the supplied engine manual before performing any operation on it.



NOTE

Running the engine without oil or with oil below the minimum level will seriously damage it.



NOTE

Oil is a harmful substance for the environment. Store it, use it and dispose of it in compliance with the legislation in force in the country where the generator is used.

Check and top up the engine oil level following the specific instructions for the engine model present on the generator. Refer to the documentation of the manufacturer of the engine before performing any operation on it.

Checking the engine oil level:

- Stop the generator and wait a few minutes for the oil to return from the piping to the engine sump.
- Refer to the supplied use and maintenance manual of the engine before performing any operation on it.

Topping up the engine oil:

- Use engine oil that the type and viscosity comply with the operating environment temperature and while the engine is running.
- Follow the instructions provided in the supplied use and maintenance manual of the engine to choose the SAE oil viscosity rating according to the external operating temperature.

6.5.2 Changing the engine oil and filter



NOTE

Whenever oil is changed, the filter must be replaced as well.

Refer to the supplied manual of the engine to change the engine oil and the oil filter.

Changing the engine oil

Refer to the supplied use and maintenance manual of the engine.

Changing the engine oil filter

Refer to the supplied use and maintenance manual of the engine.

6.5.3 Verifying the coolant level and topping up



ATTENTION

Do not open the filler cap with the engine hot. When the engine is hot, steam and boiling water could be violently ejected.



NOTE

Do not start the engine with no coolant.

Verify and top up the coolant referring to the supplied manual of the engine.

Location

In OPEN SET generators, the coolant tank is normally positioned above the radiator and can be accessed directly from the side of the engine, as shown in the photo with number (1) (purely indicative) (the shape and colour of the tank could differ depending on the version of the generator).

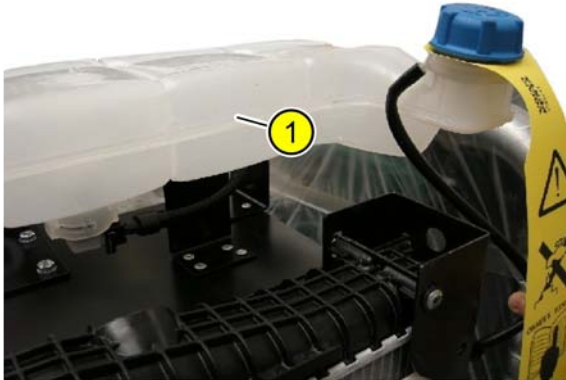

In SOUNDPROOF generators, the coolant tank can be reached by opening the filler cap (2) located on top of the bonnet.



Checking the level of coolant

- Refer to the supplied use and maintenance manual of the engine.

Topping up the coolant

- Stop the generator and wait for the engine to cool off completely (at least 1 HOUR).
- Refer to the supplied use and maintenance manual of the engine.

Changing the coolant

- Stop the generator and wait for the engine to cool off completely (at least 1 HOUR).

- Refer to the supplied use and maintenance manual of the engine.



NOTE

Refer to the engine manual to identify the position and shape of the valve to drain the coolant.

6.5.4 Replacing the coolant filter



ATTENTION

Do not open the filler cap with the engine hot. When the engine is hot, steam and boiling water could be violently ejected.

Replace the coolant filter referring to the supplied use and maintenance manual of the engine.

Replacing the coolant filter:

Refer to the supplied use and maintenance manual of the engine.

6.5.5 Replacing the air filter



NOTE

The air filter must always be clean and in good condition, otherwise it must be replaced. Eliminate old filters; old filters must not be cleaned or reused. Do not run the engine without the air filter as dust or other substances could be drawn into the engine causing premature wear and possible damage.

Replace the air filter while referring to the supplied use and maintenance manual of the engine.

Replacement:

- Stop the generator and wait for the engine to cool off completely before replacing the filter.
- Refer to the supplied use and maintenance manual of the engine.

6.5.6 Replacing the fuel pre-filter and filter



WARNING

The fuel pre-filter and filter must be replaced when the engine is cool to prevent the risk of fire caused by a fuel leak on red-hot surfaces.



NOTE

Do not fill the new filter with fuel before mounting it as impurities could enter the system causing damage and malfunctioning.

Replace the filter while referring to the supplied use and maintenance manual of the engine.

Replacing the fuel pre-filter:

- Stop the engine.
- Wait as long as is necessary for the components to cool off (at least 1 HOUR).
- Refer to the supplied use and maintenance manual of the engine.

Replacing the fuel filter

- Stop the engine.
- Wait as long as is necessary for the components to cool off (at least 1 HOUR).
- Refer to the supplied use and maintenance manual of the engine.

6.5.7 Draining fuel from the tank



WARNING

The fuel must be drained when the engine is cool, to prevent the risk of fire caused by a fuel leak on red-hot surfaces. Wait at least 1 HOUR after the generator has been switched off.



NOTE

Do not dispose of fuel in the environment. Use a suitable container to collect the fuel drained from the tank.

- Should the containment tank outside the fuel tank need to be emptied (for generators provided with containment tanks), the drain plug is near the nozzle on the tank itself.
- Empty the tank using an external pump which draws the fuel by immersing an external pipe in the tank. The pump and external pipe are not supplied with the engine as they are specific equipment.

6.6 Maintenance schedule

The maintenance interventions are divided between those on the electrical system and those on the mechanical parts. All the interventions are summarised in the following tables forming part of the routine maintenance schedule of the generator.

6.6.1 Electrical system maintenance schedule

I Inspect R Regulate, replace C Clean		
Frequency	Element to be serviced	Action
8 hours / daily	Check the connections of the utilities (cable installation, tightness of the terminals and electrolyte level in the battery) on each use.	I
	Verify that the emergency stop button works before each use.	I
40 hours weekly	Verify there is no water or condensation infiltration.	I
	Visually check the condition of the equipment and devices.	I
200 hours monthly	Verify the tightness of the cables and components.	I
	Check the state of the battery poles and the electrolyte level.	I
1000 hours six-monthly	Check the tightness of the alternator terminals	R
2000 hours yearly	Check the state of the power cable connectors	I
	Internal cleaning of the electric boards and control panel.	C
	Check the condition and/or replace the electric wires.	I

6.6.2 Maintenance schedule of the mechanical parts

The maintenance schedule is based on an average use. If the engine is activated in adverse conditions, such as heavy prolonged loads or high temperatures, or used in unusually humid or damp conditions, contact the dealer for recommendations applicable to every single requirement and use.

I Inspect R Regulate, replace C Clean		
Frequency	Element to be serviced	Action
8 hours / daily	Check the level of the coolant and oil and top up if below the minimum level.	I
200 hours monthly	Verify the tightness of the coupling screws of the silent blocks that fasten the engine and the alternator to the frame.	I
2000 hours yearly	Verify the tightness of the screws of the bonnet if the unit is closed.	I

Refer to the supplied use and maintenance manual of the engine.

7 TROUBLESHOOTING

7 TROUBLESHOOTING	44
7.1 Problems, causes and solutions	45

7.1 Problems, causes and solutions



WARNING

Perform the troubleshooting operations according to the safety information provided in this manual.

Do not try to resolve problems whose possible causes are not described in this paragraph so as to safeguard the persons exposed and prevent the generator from being damaged. Contact the qualified personnel of the manufacturer.

It does not start										Possible cause	Solution	
•	•	•	•	•	•	•	•	•	•			
The engine is running but it does not start												
It does not reach the correct operating speed												
VOLTAGE AND/OR FREQUENCY low or zero												
The auxiliary services do not work												
The generator does not produce voltage												
Low oil pressure												
High water temperatures												
Excessive speed												
Low fuel level												
Discharged battery												
Black smoke												
Noisy engine												
•											The generator is blocked following a malfunction.	Find the problem and contact the after-sales centre if necessary.
•	•										Discharged batteries.	Check and recharge the batteries. Replace them, if necessary.
•	•										Corroded or loose battery connections.	Check the cables and terminals. If the terminals and bolts are corroded, replace them. Fix them in safe conditions.
•									•		Inefficient connections, damaged batteries or battery charger.	Check the connections to the battery charger and the batteries.
•											Faulty starter motor.	Contact the after-sales assistance centre to request assistance.
•	•										No fuel.	Check the fuel tank and add fuel if there is no leakage.
	•								•		Air in fuel line.	Empty air from fuel line.
	•										Blocked fuel filter.	Replace the filter.
	•	•	•								Malfunction in the fuel system.	Contact the after-sales assistance centre to request assistance.
	•	•	•							•	Blocked air filter.	Replace the filter.
	•									•	Cold weather conditions.	Check the viscosity of the specific SAE lube oil and the fuel characteristics.
	•										Faulty speed regulator.	Contact the after-sales assistance centre to request assistance.
	•	•	•						•		Faulty voltage regulator.	Contact the after-sales assistance centre to request assistance.

It does not start										Possible cause	Solution		
The engine is running but it does not start	It does not reach the correct operating speed	VOLTAGE AND/OR FREQUENCY low or zero	The auxiliary services do not work	The generator does not produce voltage	Low oil pressure	High water temperatures	Excessive speed	Low fuel level	Discharged battery			Black smoke	Noisy engine
		•	•	•								Speed is too low.	Check the speed regulator if the engine is equipped with it. If the engine is not equipped with a mechanical speed regulator, contact the after-sales assistance centre to request assistance.
		•	•									The relative instruments are faulty.	Check and replace if necessary.
			•									Instrument connections.	Check the connections of the instruments.
			•									The switch has tripped due to overvoltage.	Reduce the overvoltage.
				•	•	•	•				•	Power surge.	Check that the generator is not in overload conditions, even in relation to the ambient temperature which could be higher than normal.
			•	•								The main switch has been activated. Short-circuit or faulty earthing.	Check all the circuits in relation to any type of machine damage or connection cables.
			•									Faulty auxiliary services.	Contact the after-sales assistance centre to request assistance.
			•									No power supply.	Check the power circuits.
											•	The oil level is high.	Remove excess oil.
					•							The oil level is low.	Add oil to restore the oil level in the engine block. Check that there is no leakage.
					•							Blocked oil filter.	Replace the filter.
					•							Faulty oil pump.	Contact the after-sales assistance centre to request assistance.
						•						The coolant level in the radiator is low.	Wait for the machine to cool off and check the liquid level in the radiator; add coolant if necessary. Check that there is no leakage.
						•						Faulty water pump.	Contact the after-sales assistance centre to request assistance.
					•	•	•	•	•			A malfunction in the relative alarm: the sensor, electric control panel or electric connections are faulty	Check the electric connections between the sensor and the panel. Verify that the electric connections of the sensor are not earthed. Check the sensor and replace it if necessary.
						•						Dirty or blocked radiator/heat exchanger.	Make sure the radiator/heat exchanger is clean. Check that no blocks occur in the air circulation or in the outlet air recirculation at the air inlet.
•	•	•	•	•	•	•	•	•	•	•	•	Other possible causes.	Contact the after-sales assistance centre for a solution.

8 PLACING OUT OF SERVICE AND SCRAPPING

8 PLACING OUT OF SERVICE AND SCRAPPING	47
8.1 Safety when placing out of service and scrapping	48
8.2 Placing out of service for long periods	48
8.3 Decommissioning and scrapping	49
8.3.1 Special waste disposal requirements	49

8.1 Safety when placing out of service and scrapping

The following are the main safety precautions which the user must comply with. However, since it is impossible to include all the dangers that could arise when placing out of service and scrapping, remember that the decision whether an operation is to be performed is strictly personal.



WARNING

Failure to comply with the instructions and precautions provided could cause serious or fatal injuries. Always follow the procedures and precautions indicated in this manual. Do not perform maintenance that is not described in this manual; contact the manufacturer.

Perform the following operations according to the safety information provided in the MAINTENANCE chapter, especially in the “Precautions for maintenance” paragraph.

8.2 Placing out of service for long periods



WARNING

The operations described below must only be carried out by specialised personnel.

The following operations require an in-depth knowledge of certain parts of the engine. See the manufacturer’s documentation of the engine for further information or if necessary, refer to specialised personnel.



NOTE

If the generator must be stored in conditions other than those described, refer to the nearest assistance centre.



NOTE

The fuel and oil used in the engine of the generator and therefore, any oil preservatives used, are harmful for the environment; dispose of them in compliance with the legislation in force in the country of use and if present, by contacting collection and disposal associations.

If the generator is not to be used for long periods of time (more than 30 days), perform the following operations to make sure it is stored and protected correctly.

Follow the specific guidelines provided in the manuals of the relative manufacturers, according to the type of engine, in order to carry out the operations correctly. The main operations that must be carried out are:

- Disconnect all the utilities.
- Empty the fuel tank completely.
- Drain the engine oil and the coolant.
- Disconnect the battery cables
- If the generator is an “*Openset*” Clean the engine and the generator and cover them with an anti-dust sheet.

Once the preparation phases are completed, store the generator, remembering the following:

- The storage place must have a temperature and humidity that comply with the data of the generator. Avoid extremely cold and/or hot/humid areas.
- The storage place must be covered and must not be dirty and exposed to dust accumulation.

8.3 Decommissioning and scrapping



WARNING

Scrapping and placing the generator out of service must be carried out by qualified personnel who work in a specialised waste treatment centre, whom to deliver the generator or who must be asked to collect it.

The generator cannot be disposed of in the environment, regardless whether intact or partially disassembled or demolished; it must be disposed of in accordance with the requirements stipulated by the applicable law in the country of use.

Application of Directive 2002/95/EC (RoHS):

- in relation to the restrictions on the use of hazardous substances, it should be noted that the electrical and electronic components used in the generator do not contain harmful or hazardous substances that exceed the legally accepted limits.
- In case of fire and/or improper use of the generator or its components, it has been verified that substances that are harmful to humans and the environment can be released.

Disposal of fuel and spent oils:

The fuel and oil used in the engine of the generator are harmful for the environment; dispose of them in compliance with the legislation in force in the country of use and if present, by contacting collection and disposal associations.

Waste is defined as any substance or object that may be the product of human activity or natural cycles, abandoned or intended to be.

The following waste categories must be considered as special waste:

- Machinery and equipment generally deteriorated and obsolete;
- Motor vehicles and their out-of-order components.

All products that contain or are contaminated with the substances indicated in the EU Directives 75/442/EC, 76/403/EC and 78/319/EC are considered as harmful-toxic waste.

8.3.1 Special waste disposal requirements

Application of Directive 2002/96/EC (WEEE):

- Waste from electrical and electronic equipment may contain hazardous substances with potentially harmful effects on the environment and human health. They must be disposed of in accordance with the legislation in force in the country of use. With reference to Directive 2002/96/EC WEEE (Waste Electrical and Electronic Equipment), the electrical and electronic components must be separated while being disposed of adequately in centres specializing in waste treatment.

9 SPECIFICATIONS

9 SPECIFICATIONS	50
9.1 Information concerning lubricants, liquids and coolants	51
9.2 Derating due to environmental conditions	53

9.1 Information concerning lubricants, liquids and coolants

Engine oil

Refer to the supplied use and maintenance manual of the engine.



NOTE

The standard equipment is supplied with SAE 15W/40 oil.

Engine oil viscosity

Refer to the supplied use and maintenance manual of the engine.



NOTE

Pure mineral oils or partially synthetic oils can be used as long as the above-mentioned quality criteria are complied with.

***Refer to the supplied manual of the engine where you will find further details for starting up the engine.**

Fuel

The fuel must comply with the national and international standards regarding commercial fuels.

Refer to the supplied use and maintenance manual of the engine.

Sulphur content:

In compliance with the law, if the sulphur content is greater than 0.5%, the periodic oil changes must be altered. Keep in mind that fuels with minimum sulphur content can cause a loss of power (approximately 5%) and increase consumption by 2 or 3%.

Engine coolant

The radiator coolant even protects against internal corrosion, cavitation, erosion and damage caused by freezing. Different additives can also be mixed to improve the characteristics of the coolants.

**NOTE**

The standard supply includes the following coolant: a mixture of 30% antifreeze concentrated in 70% water. This composition allows coolant to withstand a minimum temperature of -17.5 °C before freezing.

When changing coolant, make sure the technical specifications indicated in the supplied manual of the engine are complied with.

**NOTE**

The amount of concentrated antifreeze to be mixed with water must not exceed 60%.

Mixing over 60% concentrated antifreeze with water could reduce the efficiency of the heat exchange between the engine and the coolant, thereby posing a risk of overheating the engine and resulting in less protection of the liquid from freezing.

The coolant must be mixed with clear water: always use distilled deionised water. The water must always conform to the requirements specified in the supplied use and maintenance manual of the engine.

**NOTE**

It is very important to add the correct concentration of antifreeze. The mixture should be prepared beforehand in another container before being used to fill the radiator system. Make sure that the liquids can be mixed.

***Refer to the supplied manual of the engine where you will find further details for starting up the engine.**

9.2 Derating due to environmental conditions

Performance could be subject to “derating” with respect to the nominal values as a result of the environmental conditions being different from the nominal conditions stipulated by the reference standard (ISO8528-1), such as different temperature, altitude and humidity. This applies to both the engine and the alternator it is coupled to and therefore, for the overall performance of the generator.

It is important for the user or customer to clearly inform the manufacturer concerning the environmental conditions in which the generator will operate just as performance reduction and “derating” of the generator must be established when placing the order. This will make it possible to appropriately adjust the engine and alternator before being commissioned.

It is very important for the user or customer to specify the following data (ref. ISO8528-1) when indicating the environmental conditions in which the generator will operate: ISO8528-1):

- The minimum and maximum barometric pressure at the installation site or the altitude above sea level.
- The minimum, maximum and average monthly temperature during the coldest and hottest months of the year.
- The lowest and highest ambient temperature around the generator engine.
- The relative humidity, the water vapour pressure or wet and dry bulb temperatures, measured at the maximum ambient temperature.
- Any other environmental condition which could require special solutions or more frequent maintenance cycles, such as:
 - Environments full of dust and/or sand
 - Marine environments
 - Environments with particularly high solar radiation
 - Environments with the possibility of chemical pollution
 - Environments with the presence of radiations
 - Operating conditions in the presence of strong vibrations (for example, zones affected by earthquake or vibrations generated by nearby equipment).

Contact the generator manufacturer should you require further details concerning derating due to environmental conditions.

